

## DubbeloPP

- Distance between bikes heart-to-heart is 375 or 400 mm
- Modular design, length 300 cm
- All steel parts are hot-dipped galvanized
- Available in steel or powder coated in any RAL color (depending on ordersize)
- Stand alone mounting on column bases or baseplates
- Space saving
- Easy to use, customer friendly
- 3 points of support for the parked bicycle
- Handle in contrasting colors

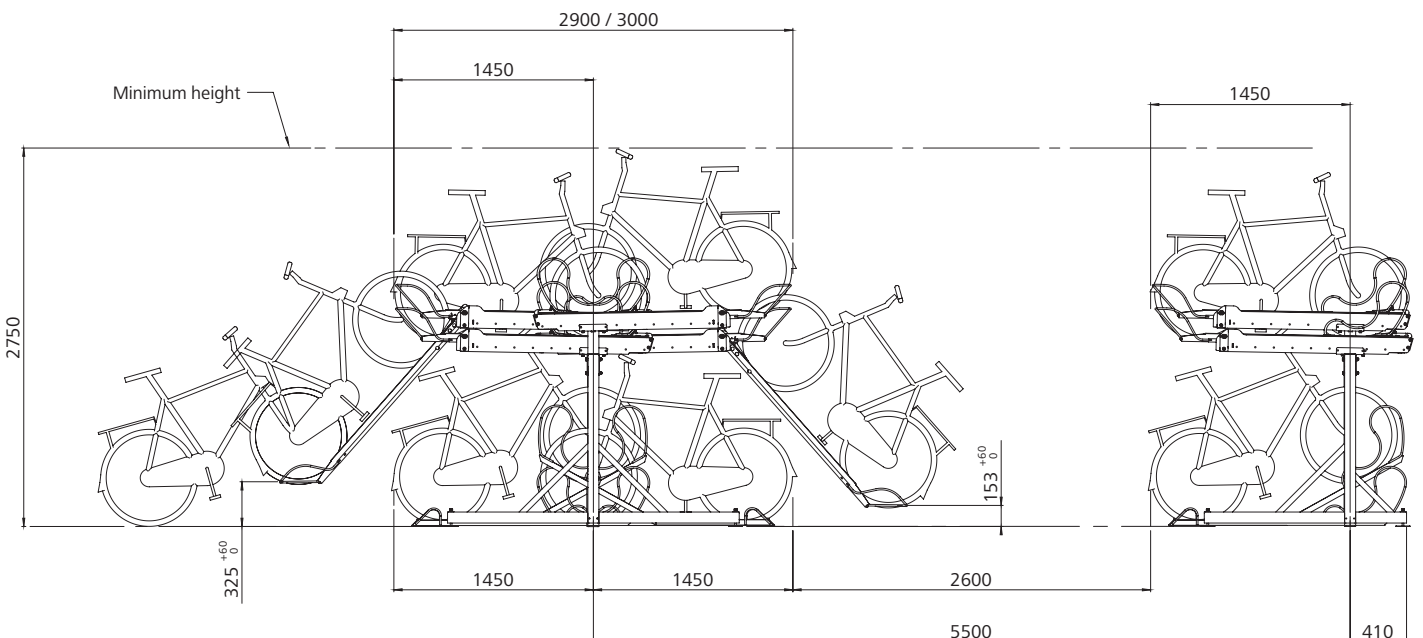

### Armada Mobility BV

Groninghaven 2  
 3433 PE Nieuwegein, NL  
**T** +31 (0)30 - 246 95 00  
**F** +31 (0)30 - 246 95 01  
**E** [info@armadamobility.nl](mailto:info@armadamobility.nl)  
**I** [www.armadamobility.nl](http://www.armadamobility.nl)





## Modular system

The DubbeloPP bicycle storage system is a modular system in which the capacity can be adjusted to the available space. The standard module is three meters wide. For smaller areas, it is also possible to place smaller modules. The distance between two bicycle places heart-to-heart is 375 mm, 400 mm, or any other desired distance. The system is standard hot-dip galvanized and can be powder coated in any RAL color.

The DubbeloPP bicycle storage system is approved by Dutch FietsParKeur council and is very ergonomic. Due to use of sustainable materials the DubbeloPP system has a long operational life. The system is easy to clean due to the open design. It can be cleaned in a very easy way with only water. The DubbeloPP system is designed for the user, to make it easy to install a bicycle.

## User-friendly and safe

The most important requirements for a user of a bicycle are the ease of use and the safety of the system. The design of the DubbeloPP is therefore based on these two needs. The bicycle can be parked in a very easy way:

- The user places the bicycle directly in the rack, or uses the second floor.
- To place a bike on the second floor a rail can be pulled down.

- The required power is only 10 kilo's !!
- Then the bicycle can be placed. Because of an intelligent connective system on the rail the bike is fully supported at three points so the front fork and the rear wheel can not deform.
- Next step is to move the rail upwards and bring forward with a force of only 15 kilo's.
- The bike is now stable and safely parked on the second floor.
- By pulling out and guiding down the rail, you can take the bike back out of the storage.

During the development of the system safety requirements were as important as the user-friendly requirements. To ensure safety, DubbeloPP has been designed with round shapes in the handle and gutters. The moving parts which makes the use of the rack so easy, are shielded. The ergonomic handle has a contrasting colour to be distinctive. It more or less guides the user to use it. The DubbeloPP bicycle storage system is a space-saving solution which can be easily used in every space, indoor or outdoor.